

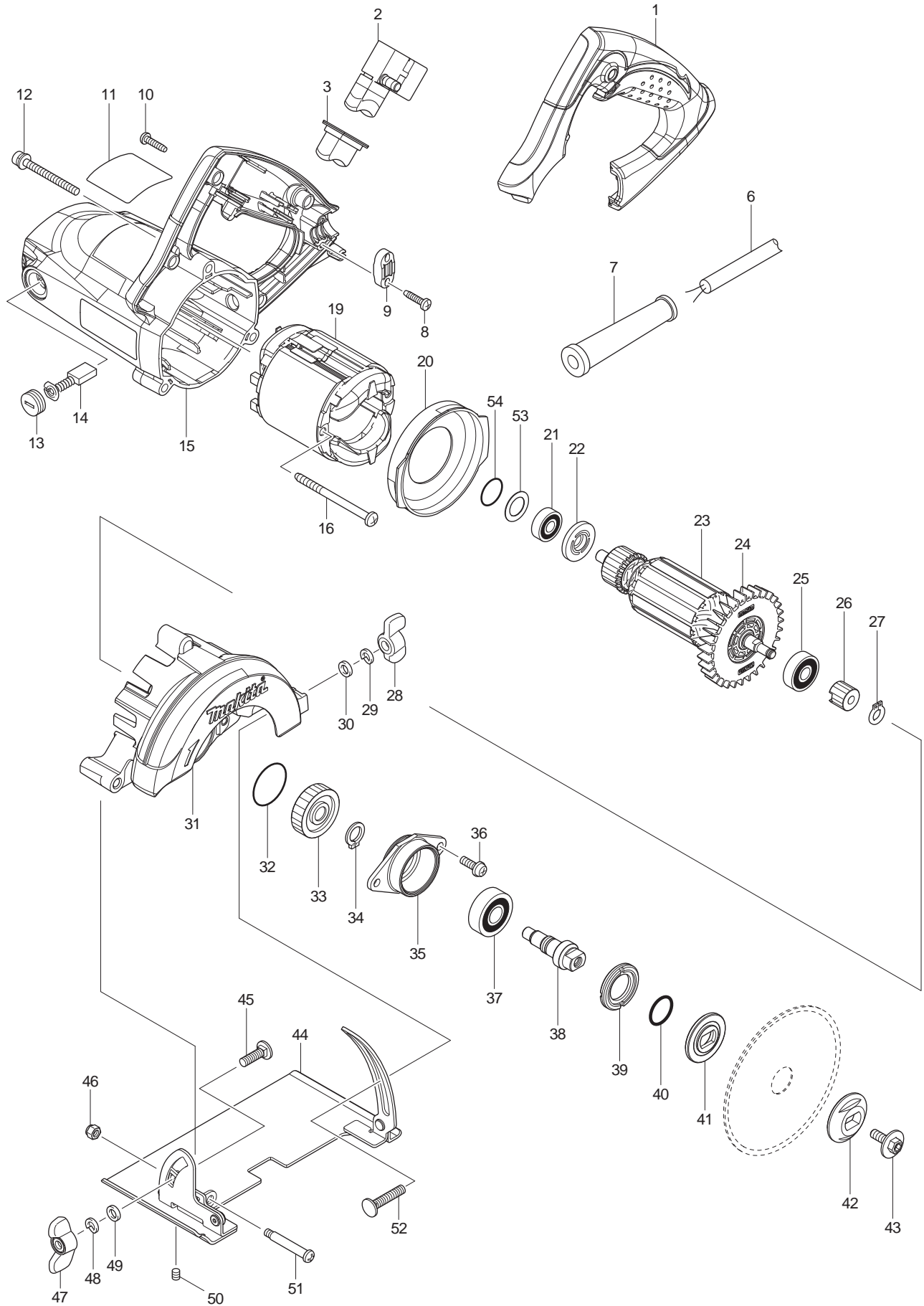

04 - 2012
4100NH2ZX1
4" MASONRY SAW



PARTS LIST

Item No	Type	Part No	Description	Qty	Unit
001	2	413B57-8	* HANDLE COVER	1	PC.
001	3	450838-7	* HANDLE COVER	1	PC.
002	2	650248-0	SWITCH SGES115C-3	1	PC.
003	3	424585-6	DUST COVER	1	PC.
006		664265-4	CORD WITH PLUG 2P-16-2.5M SJ	1	PC.
007	2	682574-9	CORD GUARD 10-90	1	PC.
008	3	265995-6	TAPPING SCREW 4X18	2	PC.
009	2	687123-7	STRAIN RELIEF	1	PC.
010	3	265995-6	TAPPING SCREW 4X18	4	PC.
011		897639-6	NAME PLATE F/4100NH2	1	PC.
012	3	911263-2	PAN HEAD SCREW M5X40	3	PC.
013	3	643750-0	BRUSH HOLDER CAP 7-11	2	PC.
014		194996-6	CARBON BRUSH CB-303 2PC/SET	1	SET
015	1	141728-2	* MOTOR HOUSING COMPLETE	1	PC.
015	1	INC. 643708-9	* BRUSH HOLDER 5-11	2	PC.
015	1	INC. 892784-2	* CAUTION LABEL, FR/SP	1	PC.
015	3	141R43-2	* MOTOR HOUSING COMPLETE	1	PC.
015	3	INC. 643708-9	* BRUSH HOLDER 5-11	2	PC.
015	3	INC. 892784-2	* CAUTION LABEL, FR/SP	1	PC.
016	3	266038-7	TAPPING SCREW 5X70	2	PC.
019		594581-9	FIELD ASSY 115V	1	PC.
019		INC. 654020-2	RING TERMINAL	2	PC.
019	2	INC. 654485-8	PARALLEL SPLICE	2	PC.
020		450839-5	BUFFLE PLATE	1	PC.
021		211395-8	BALL BEARING 608LLU	1	PC.
022		681644-1	INSULATION WASHER	1	PC.
023	2	518192-6	ARMATURE ASS'Y 115V	1	PC.
023	2	INC.	Item No. 21, 22, 24, 25	1	PC.
024		240109-8	FAN 70	1	PC.
025		211092-6	BALL BEARING 629DDW	1	PC.
026		226695-3	HELICAL GEAR 17	1	PC.
027		961002-0	RETAINING RING S-6	1	PC.
028		252649-4	THUMB NUT M6	1	PC.
030		941151-9	FLAT WASHER 6	1	PC.
031	2	142541-1	* BLADE CASE COMPLETE	1	PC.
031	2	INC. 213445-5	O-RING 26	1	PC.
031	2	INC. 212046-6	NEEDLE BEARING 810	1	PC.
032		213444-7	O RING 30	1	PC.

Item No	Type	Part No	Description	Qty	Unit
033		226696-1	HELICAL GEAR 44	1	PC.
034		961052-5	RETAINING RING S-12	1	PC.
035	2	319044-2	* BEARING BOX	1	PC.
036		911223-4	PAN HEAD SCREW M5X16	2	PC.
037		211129-9	BALL BEARING 6201DDW	1	PC.
038		325603-2	SPINDLE	1	PC.
039	2	285858-0	* BEARING RETAINER 19-33	1	PC.
040		213279-6	O RING 18	1	PC.
041		224423-0	INNER FLANGE 36	1	PC.
042		224424-8	OUTER FLANGE 36	1	PC.
043		266510-9	HEX. SOCKET HEX. BOLT M6X18	1	PC.
044		165548-0	BASE	1	PC.
045	2	265939-6	FLAT HEAD SQ NECK BOLT M6X14	1	PC.
046		252103-8	HEX. LOCK NUT M5-8	1	PC.
047		252649-4	THUMB NUT M6	1	PC.
049		941151-9	FLAT WASHER 6	1	PC.
050		266264-8	H.S.SET SCREW(FLAT POINT)M5X6	1	PC.
051	2	265056-2	+ PAN HEAD SCREW M5	1	PC.
052		251920-3	CAP SQUARE NECK BOLT M6X30	1	PC.
053		253192-6	FLAT WASHER 14	1	PC.
054		213262-3	O RING 18	1	PC.
100		455133-0	* SPONGE (Added)	1	PC.
A01	2	781041-2	WRENCH 22	1	PC.
A02	2	783217-7	HEX. WRENCH 5	1	PC.
A03	2	B-69680	4" TURBO RIM DIAMOND WHEEL	1	PC.
A04		D-36968	4-3/8" CURVED DIAMOND WHEEL 20MM, DRY	1	PC.
A05		198673-2	GUIDE RAIL ADAPTER SET	1	PC.
C01		873698-4	CARTON F/4100NH2X1	1	PC.
D01		652008-6	PAN HEAD SCREW M3.5X7	2	PC.
D02		654037-5	INSULATED EYE TERMINAL FT1.25-M3	2	PC.
D03		654509-0	CONNECTOR 2-SD	1	PC.
E03		424634-9	* SPONGE	1	PC.
E04		683004-3	* VINYL TUBE 8-40	1	PC.
F01		194925-9	GUIDE RAIL 1900MM	1	PC.
F02		199140-0	GUIDE RAIL 1000MM	1	PC.
F03		199141-8	GUIDE RAIL 1500MM	1	PC.
F04		196943-3	BASE COVER SET	1	PC.
F06		198673-2	198673-2	1	PC.
F12		194368-5	GUIDE RAIL 1400MM	1	PC.

Item No	Type	Part No	Description	Qty	Unit
F14		194367-7	GUIDE RAIL 3000MM	1	PC.
F15		194416-0	VINYL SHEET 384" (10000MM)	1	PC.
F16		194417-8	RUBBER SHEET 384" (10000MM)	1	PC.
F17		194418-6	RUBBER POSITION SHEET 55" (1400MM)	1	PC.

SERVICE CHANGES: 4100NH2

1. Changes on Bearing box and Bearing retainer

(TI#A1058)

Item No.	Description	Type 1	Type 2
35	Bearing box	318346-3	319044-2
39	Bearing retainer 19-33	285834-4	285858-0

Above parts are completely interchangeable as a set.

Type 1

Type 2

① Bearing box

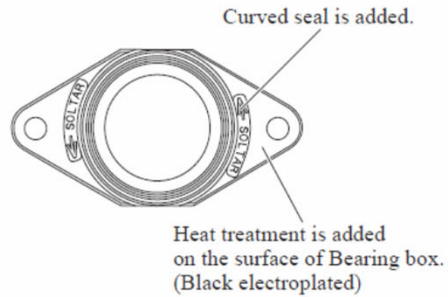
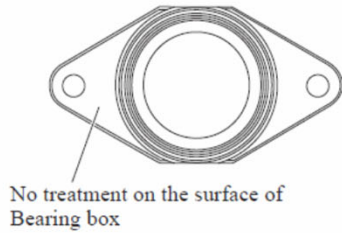

② ③ Bearing retainer 19-33

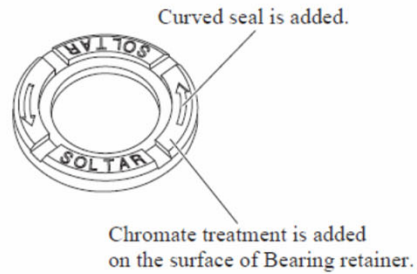
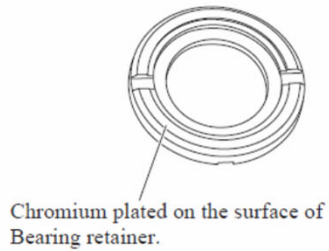

2. Addition of Sponge

(TI#A2622)

(TI#Z52820)

Item No.	Description	Type 1	Type 2
100	Sponge	455133-0	424634-9

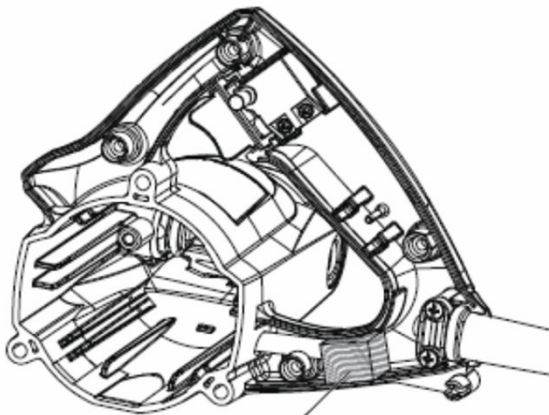

Sponge (455133-0)

3. Changes on Motor housing com. and Handle cover

(TI#DC567)

(TI#Z52820)

Item No.	Description	Type 1	Type 2	Type 3
15	MOTOR HOUSING COM.	141728-2	141K36-7	141R43-2
1	HANDLE COVER	450838-7	413B57-8	450838-7
E04	VINYL TUBE 8-40	-----		683004-3

Above parts are completely interchangeable as a set.

(Vinyl tube to protect lead wires from Motor housing opening can be eliminated when using Type 2.)

Motor housing complete

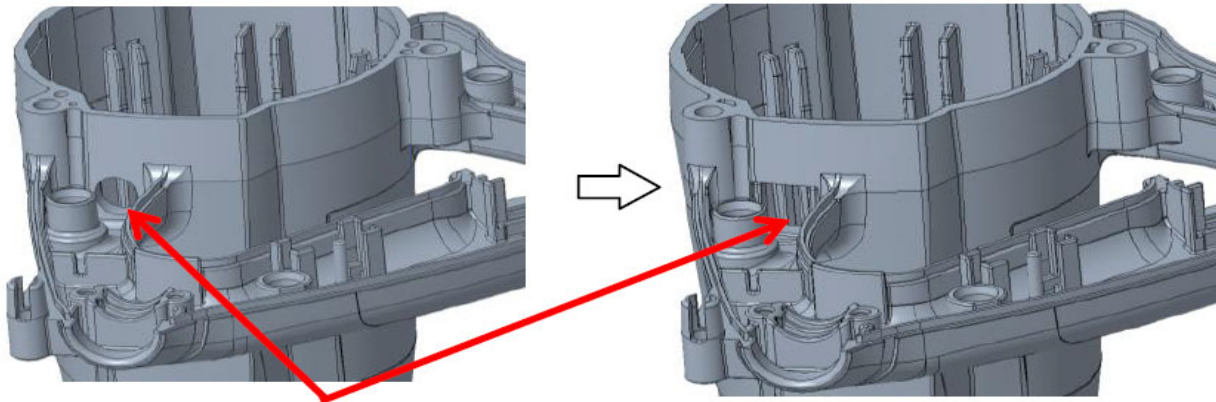

Round opening to pull out lead wires from the inside will be changed to square.

Handle cover

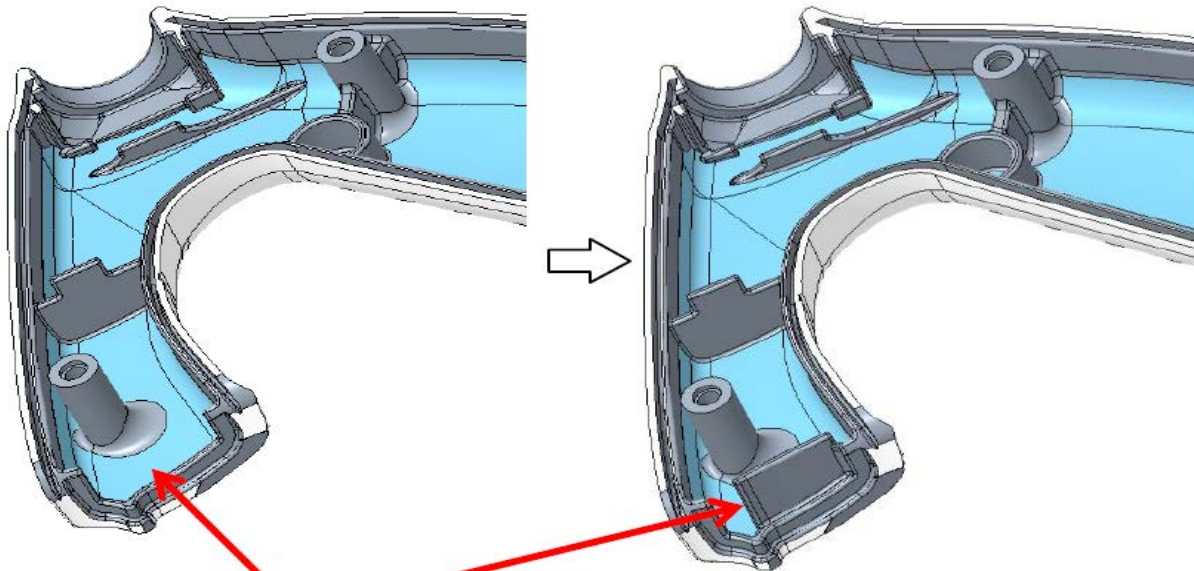

Rib will be added to hold Lead wires.